

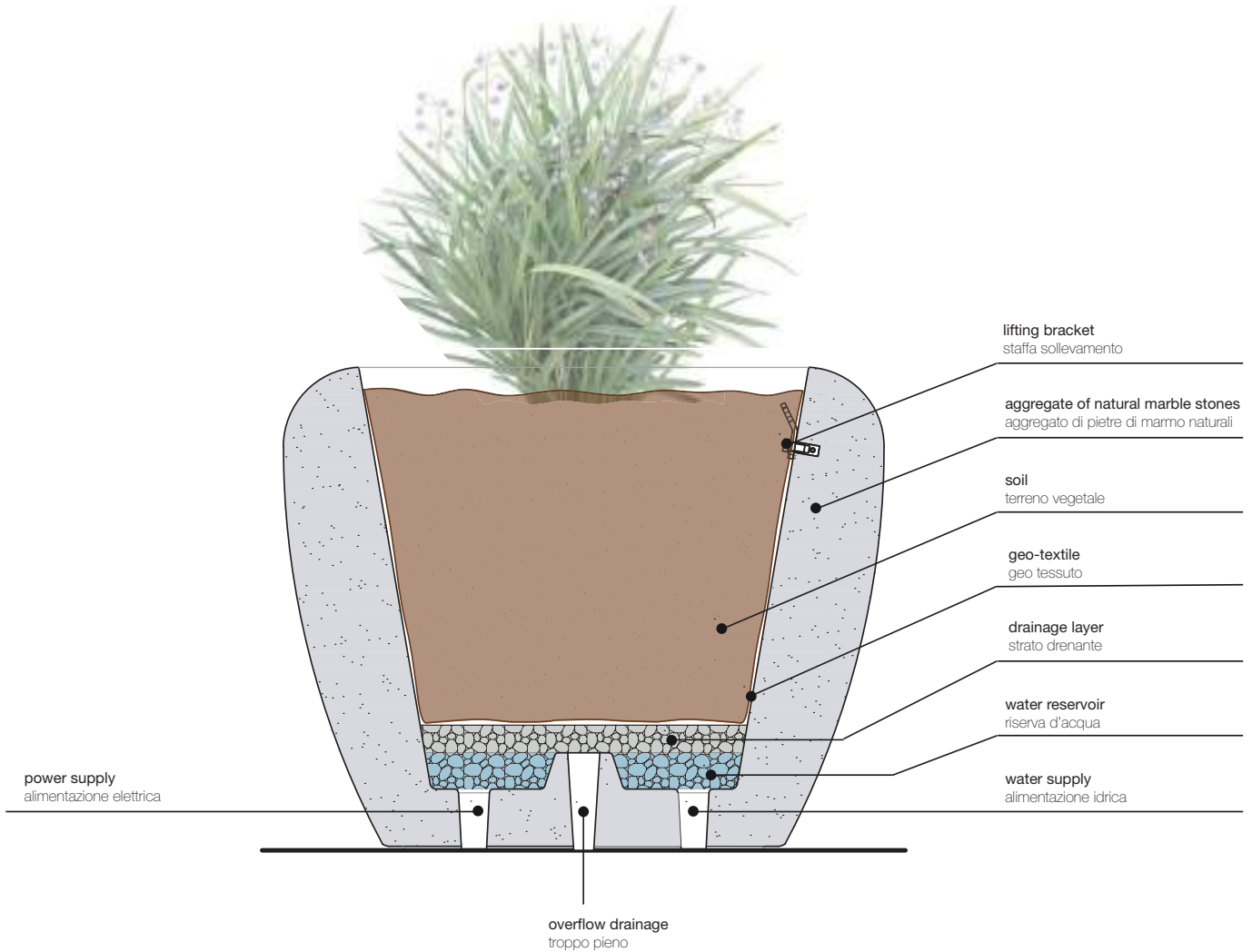

PIANETI COLLECTION





The planters of the collection PLANETI are equipped with water reserve system (except Marte*), overflow discharge and hole for passage electrical and/ or hydraulic systems. Each planter is equipped with three brackets for handling with bands or chains.

Le fioriere della collezione PLANETI sono dotate di sistema di riserva d'acqua (eccetto Marte*), scarico del troppo pieno e foro per passaggio impianti elettrici e/o idraulici. Ogni fioriera è dotata di tre staffe per la movimentazione con fasce o catene.

Las jardineras de la colección PLANETI están equipadas con sistema de reserva de agua (excepto Marte*), desagüe rebosadero y orificio para paso de instalaciones eléctricas y/o de fontanería. Cada jardinera está equipada con tres soportes para manipulación con cintas o cadenas.

Les jardinières de la collection PLANETI sont équipées d'un système de réserve d'eau (sauf Marte*), d'une décharge de trop-plein et d'un trou pour les installations électriques et/ou hydrauliques. Chaque jardinière est équipée de trois supports pour la manipulation avec des bandes ou des chaînes.



PIANETI

BELLITALIA DESIGN

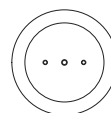
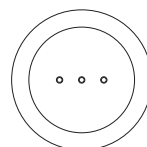
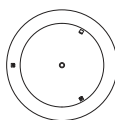

LUNA*

Ø 830 mm
H 520 mm
360 kg
85 lt

VENERE*

Ø 1153 mm
H 590 mm
800 kg
172 lt

GIOVE*

Ø 1500 mm
H 735 mm
1500 kg
489 lt

MARTE

Ø 1900 mm
H 1100 mm
3005 kg
1.212 lt

SATURNO*

Ø 1495 mm
H 1198 mm
2393 kg
805 lt

MATERIALS / MATERIALI / MATERIALES / MATÉRIAUX:

PIETRE PREZIOSE

GRANITO



FINISHING / FINITURE / ACABADOS / FINITIONS:



ACCESSORIES / ACCESSORI / ACCESORIOS / ACCESSOIRES:













САНКТ-ПЕТЕРБУРГСКИЙ
НАЦИОНАЛЬНЫЙ ЦЕНТР
НАУКИ И ОБРАЗОВАНИЯ





PIANETI CO with Mura



COLLECTION

ano Glass



PIANETI with Murano Glass



The area in which Venice stands has always been the point of arrival of all maritime trade with the eastern coasts of the Mediterranean and glass has always enjoyed a central role.

The Venetian glassmakers of Murano Island, had a real development around the X century, sensing the malleability of glass and its ability to be blown and modelled in the incandescent state, but capable of maintaining the same chromatic characteristics. From the XIX century, the Murano glassworks began to develop new techniques, still in use today, pushing glass processing towards contemporary art and product design. The magic of Murano glass is contained in its own secret island, which has kept the industrial secrets for centuries, creating unique products in the world.

L'area in cui sorge Venezia è sempre stata il punto di arrivo di tutti gli scambi marittimi con le coste orientali del Mediterraneo e il vetro in particolare, ha sempre goduto di un ruolo centrale.

I vetrai Veneziani dell'isola di Murano ebbero un vero e proprio sviluppo a partire dal X secolo, intuendo la malleabilità del vetro e la sua capacità di essere soffiato e modellato allo stato incandescente, ma capace di mantenere le stesse caratteristiche cromatiche.

Dal XIX secolo i vetrai di Murano iniziarono ad elaborare nuove tecniche, tutt'oggi in uso, spingendo la lavorazione del vetro verso l'arte contemporanea e il product design. La magia del vetro di Murano è racchiusa nella sua stessa isola, che custodisce da secoli i segreti industriali di un prodotto unico al mondo.

La zona en la que se encuentra Venecia siempre ha sido el punto de llegada de todos los intercambios marítimos con las costas orientales del Mediterráneo y el vidrio en particular, siempre ha tenido un papel central.

Los vidrieros venecianos de la isla de Murano tuvieron un gran desarrollo a partir del siglo X, intuendo la maleabilidad del vidrio y su capacidad para ser soplado y modelado en estado incandescente, pero capaz de mantener las mismas características cromáticas.

A partir del siglo XIX, los vidrieros de Murano comenzaron a desarrollar nuevas técnicas, aún en uso hoy en día, empujando el procesamiento del vidrio hacia el arte y el diseño de productos contemporáneos. La magia del cristal de Murano está contenida en su propia isla, que durante siglos ha guardado los secretos industriales de un producto único en el mundo.

La région où se trouve Venise a toujours été le point d'arrivée de tous les échanges maritimes avec les côtes orientales de la Méditerranée et le verre en particulier a toujours joué un rôle central.

Les verriers vénitiens de l'île de Murano ont connu un véritable développement à partir du Xe siècle, sentant la malléabilité du verre et sa capacité à être soufflé et façonné à l'état incandescent, mais capable de conserver les mêmes caractéristiques chromatiques.

À partir du XIXe siècle, les verriers de Murano ont commencé à élaborer de nouvelles techniques, encore utilisées aujourd'hui, poussant le travail du verre vers l'art contemporain et le design produit. La magie du verre de Murano est contenue dans son île, qui conserve depuis des siècles les secrets industriels d'un produit unique au monde.



PIANETI with Murano Glass



Bellitalia® has chosen to collaborate with a trusted partner, Ekonya, to create the planters of the PIANETI collection with an eco-sustainable cement mixture containing aggregates of various colors, obtained from the recovery of Murano glass processing. Ekonia values environmental sustainability and aesthetics. Therefore, it uses binders in its concrete from the dust of semi-finished products from the cast iron industry, a choice that considerably reduces their environmental impact. The production process replicates the natural rock formation process with innovative industrial technology, creating a product whose technical properties equal those of Portland cement. In 2020, the company was selected as one of the best European startups contributing to reduce climate change.

Bellitalia® ha scelto di collaborare con un partner di fiducia, Ekonia, per realizzare le fioriere della collezione PIANETI con un conglomerato cementizio ecosostenibile contenente inerti, di vari colori, ottenuti dal recupero della lavorazione del vetro di Murano. Ekonia ha come valori la sostenibilità ambientale e l'estetica. Per questo, nel suo calcestruzzo, utilizza leganti provenienti dalle polveri dei semilavorati dell'industria della ghisa, scelta che riduce in modo considerevole il loro impatto ambientale. Il processo produttivo replica il processo di formazione naturale della roccia, con un'innovativa tecnologia industriale, creando però un prodotto le cui qualità tecniche eguagliano quelle del cemento Portland. Nel 2020 la società è stata selezionata tra le migliori startup europee che contribuiscono a ridurre i cambiamenti climatici.

Bellitalia® ha elegido colaborar con un colaborador de confianza, Ekonia, para realizar los floreros de la colección PIANETI con un hormigón ecosostenible, que contiene áridos de varios colores, obtenidos a partir de la recuperación del labrado del vidrio de Murano. Los valores de Ekonia son la sostenibilidad ambiental y la estética. Por esto, en su hormigón, utiliza aglutinantes procedentes de polvos de productos semimanufacturados de la industria de la fundición, una elección que reduce enormemente su impacto ambiental. El proceso de producción replica el proceso de formación natural de la roca, a través de una tecnología innovadora industrial, pero creando un producto con cualidades técnicas iguales a las del cemento Portland. En 2020, la sociedad fue seleccionada una de las mejores startups europeas, que contribuyen a reducir los cambios climáticos.

Bellitalia® a choisi Ekonia, un partenaire de confiance, pour réaliser les jardinières de la collection PIANETI avec un conglomerat cimenté écologique se composant de granulats inertes, de plusieurs couleurs, provenant de la récupération de traitement de verre de Murano. Les valeurs de Ekonia sont la durabilité environnementale et l'esthétisme. C'est pour cela que l'entreprise utilise pour son béton des liants provenant de poudres de produits semi-finis issus de l'industrie de la fonte, un choix qui réduit considérablement l'impact environnemental. Le processus de production reproduit le processus de formation naturelle de la roche, par une technologie industrielle innovante, en créant toutefois un produit dont les qualités techniques égalent celles du ciment Portland. En 2020, la société a été sélectionnée parmi les meilleures startups européennes qui contribuent à réduire les changements climatiques.







MARTE with Murano Glass



GIOVE with Murano Glass

Murano Bianco



Murano Grigio





VENERE with Murano Glass



LUNA with Murano Glass

PIANETI with Murano Glass

Murano Antracite

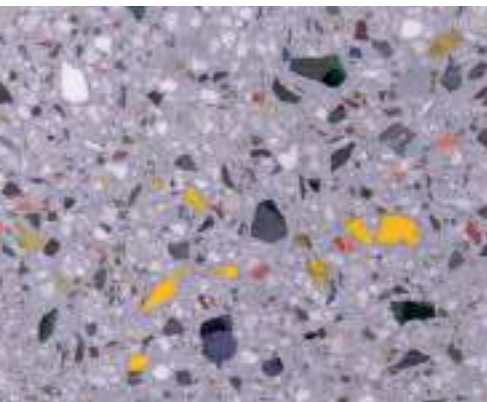



CLIMB

IVANO DESIGN

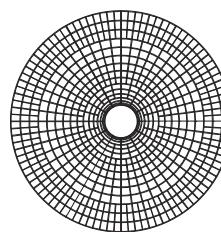
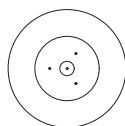
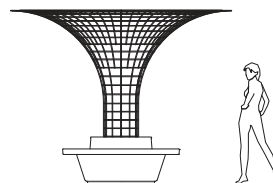
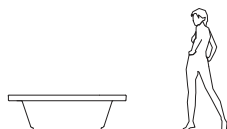

Ø 1700 mm
H 500 mm
900 kg
250 lt

Ø 3390 mm
H 2520 mm
1070 kg
320 lt

MATERIALS / MATERIALI / MATERIALES / MATÉRIAUX:

PIETRE PREZIOSE

GRANITO



FINISHING / FINITURE / ACABADOS / FINITIONS:



ACCESSORIES / ACCESSORI / ACCESORIOS / ACCESSOIRES:









CLIMB

IVANO DESIGN





A photograph of a modern urban courtyard. In the foreground, a large, dark, rounded ceramic planter holds a lush green plant. The courtyard is paved with light-colored rectangular tiles. In the middle ground, there is a green lawn area. The background features a city skyline with several tall buildings under a bright blue sky with scattered white clouds. The text "ALONE COLLECTION" is overlaid in white, bold, sans-serif font across the center of the image.

ALONE COLLECTION



TALL - LOW

BELLITALIA DESIGN



TALL

L 600 mm
W 600 mm
H 1000 mm
477 kg
140 lt

LOW

L 1000 mm
W 800 mm
H 600 mm
521 kg
214 lt

MATERIALS / MATERIALI / MATERIALES / MATÉRIAUX:

PIETRE PREZIOSE

GRANITO



FINISHING / FINITURE / ACABADOS / FINITIONS:



ACCESSORIES / ACCESSORI / ACCESORIOS / ACCESSOIRES:





TALL - LOW

BELLITALIA DESIGN





ORIONE - PEGASO

BELLITALIA DESIGN



ORIONE

Ø 520 mm
H 816 mm
242 kg
13 lt

PEGASO

Ø 640 mm
H 912 mm
374 kg
26 lt



MATERIALS / MATERIALI / MATERIALES / MATÉRIAUX:

PIETRE PREZIOSE

GRANITO



FINISHING / FINITURE / ACABADOS / FINITIONS:



ACCESSORIES / ACCESSORI / ACCESORIOS / ACCESSOIRES:





LONG - SHORT

BELLITALIA DESIGN

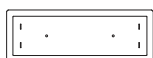

LONG

L 1980 mm
W 700 mm
H 600 mm
660 kg
483 lt

SHORT

L 1500 mm
W 800 mm
H 650 mm
850 kg
437 lt

MATERIALS / MATERIALI / MATERIALES / MATÉRIAUX:

PIETRE PREZIOSE

GRANITO



FINISHING / FINITURE / ACABADOS / FINITIONS:



ACCESSORIES / ACCESSORI / ACCESORIOS / ACCESSOIRES:









LONG - SHORT

BELLITALIA DESIGN





BERRY

BELLITALIA DESIGN

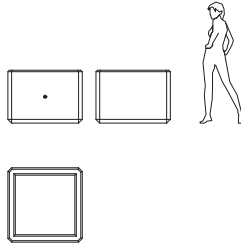

L 1000 mm
W 1000 mm
H 711 mm
760 kg
391 lt



MATERIALS / MATERIALI / MATERIALES / MATÉRIAUX:
PIETRE PREZIOSE GRANITO

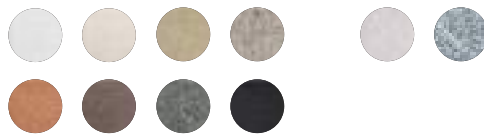

FINISHING / FINITURE / ACABADOS / FINITIONS:

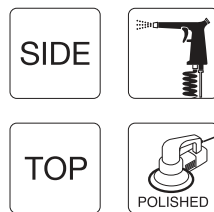

ACCESSORIES / ACCESSORI / ACCESORIOS / ACCESSOIRES:





CORVARA

BELLITALIA DESIGN

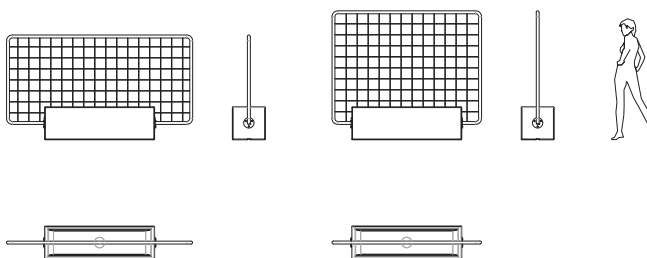

L 2540 mm
 l 1500 mm
 W 450 mm
 H 1430 mm
 325 kg
 170 lt

L 2040 mm
 l 1500 mm
 W 450 mm
 H 1760 mm
 325 kg
 170 lt

MATERIALS / MATERIALI / MATERIALES / MATÉRIAUX:

PIETRE PREZIOSE



GRANITO



POWDER COATED STEEL
 ACCIAIO VERNICIATO
 ACERO PINTADO
 ACIER THERMOLAQUÉ



FINISHING / FINITURE / ACABADOS / FINITIONS:



ACCESSORIES / ACCESSORI / ACCESORIOS / ACCESSOIRES:









18

19

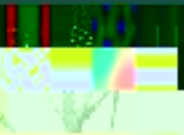

20

21

22

23

COROLLA

BELLITALIA DESIGN

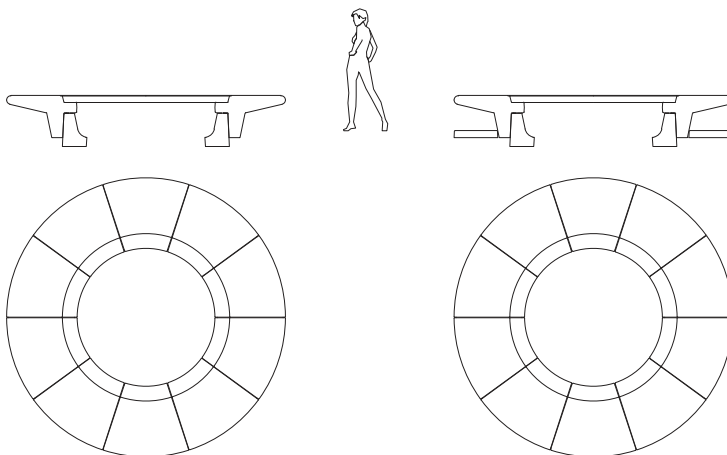

Ø 4000 mm
H 500 mm
7585 kg
1.594 lt

Ø 4000 mm
H 500 mm
9005 kg
1.594 lt

MATERIALS / MATERIALI / MATERIALES / MATÉRIAUX:

PIETRE PREZIOSE

GRANITO



FINISHING / FINITURE / ACABADOS / FINITIONS:



ACCESSORIES / ACCESSORI / ACCESORIOS / ACCESSOIRES:









CASSIOPEA

BELLITALIA DESIGN

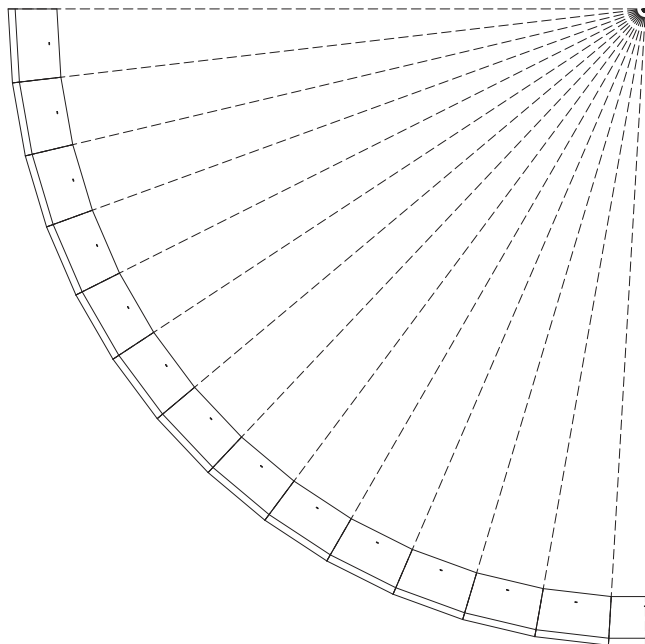
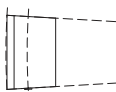
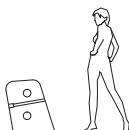

Ri 7790 mm
 Re 8430 mm
 L 979 mm
 W 644 mm
 H 675 mm
 750 kg
 12.850 lt

MATERIALS / MATERIALI / MATERIALES / MATÉRIAUX:

PIETRE PREZIOSE

GRANITO



FINISHING / FINITURE / ACABADOS / FINITIONS:



ACCESSORIES / ACCESSORI / ACCESORIOS / ACCESSOIRES:









PLANTERS
FIORIERE
JARDINERAS
JARDINIÈRES

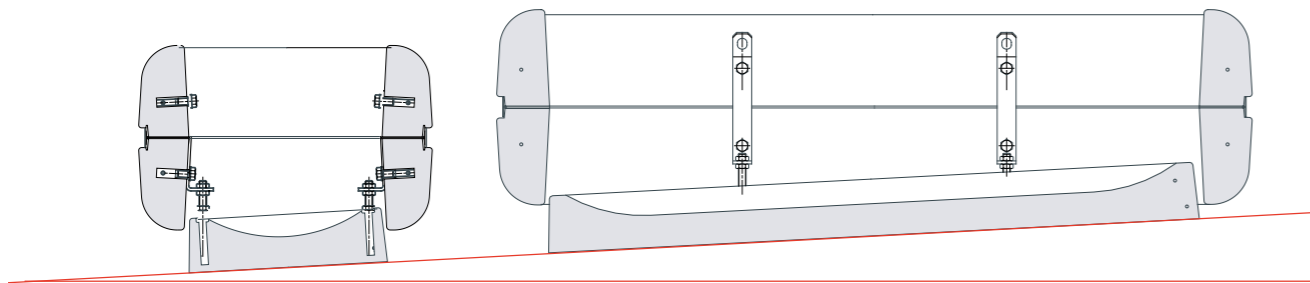

UNTIL **6%**

The leveling system is one of the main patented features that has made Bellitalia® products famous. This feature compensates for sloping ground with a gradient of up to 6%, achieving a levelled effect from a visual point of view.

Uno dei principali sistemi funzionali brevettati che hanno reso famosi i prodotti di Bellitalia®, è sicuramente il sistema di livellamento. Esso permette di compensare la pendenza del terreno fino ad un massimo del 6% ottenendo un effetto piano da un punto di vista visivo.

CRISTINA α - β WITH LEVELING SYSTEM

BELLITALIA DESIGN

Uno de los principales sistemas funcionales patentados que han hecho famosos a los productos Bellitalia® es, sin duda, el sistema de nivelación. Permite compensar la pendiente del suelo hasta un máximo del 6% obteniendo un efecto plano desde un punto de vista del conjunto.

Bellitalia® doit son succès aussi à un système breveté pour niveler le produit au sol: la pente du terrain jusqu'à 6% ainsi compensée horizontalement donne l'effet d'un élément posé droit.

CRISTINA α - β

BELLITALIA DESIGN







CRISTINA α - β

BELLITALIA DESIGN

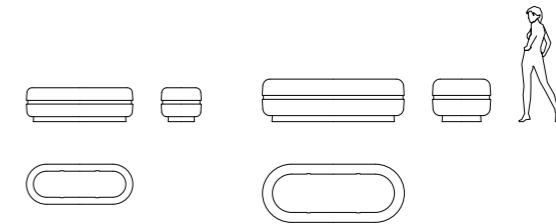
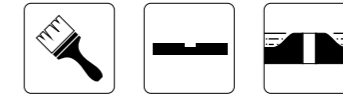

ALPHA
 L 1500 mm
 W 565 mm
 H 478 mm
 350 kg
 177 lt

BETA
 L 2000 mm
 W 820 mm
 H 600 mm
 880 kg
 410 lt



MATERIALS / MATERIALI / MATERIALES / MATÉRIAUX:

NATURAL MARBLE STONES	WHITE GRANITE	GREY CONCRETE
PIETRE DI MARMO NATURALI	GRANITO BIANCO	CEMENTO GRIGIO
PIEDRAS DE MÁRMOL NATURAL	GRANITO BLANCO	HORMIGÓN GRIS
PIERRES DE MARBRE NATURELLES	GRANIT BLANC	CIMENT GRIS



FINISHING / FINITURE / ACABADOS / FINITIONS:



ACCESSORIES / ACCESSORI / ACCESORIOS / ACCESSOIRES:





MENHIR

BELLITALIA DESIGN

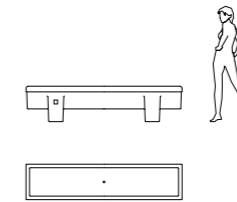
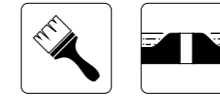

L 2200 mm
W 500 mm
H 500 mm
380 kg
115 lt



MATERIALS / MATERIALI / MATERIALES / MATÉRIAUX:

NATURAL MARBLE STONES	WHITE GRANITE	GREY CONCRETE
PIETRE DI MARMO NATURALI	GRANITO BIANCO	CEMENTO GRIGIO
PIEDRAS DE MÁRMOL NATURAL	GRANITO BLANCO	HORMIGÓN GRIS
PIERRES DE MARBRE NATURELLES	GRANIT BLANC	CIMENT GRIS



FINISHING / FINITURE / ACABADOS / FINITIONS:

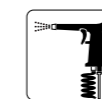

ACCESSORIES / ACCESSORI / ACCESORIOS / ACCESSOIRES:



MUG
BELLITALIA DESIGN



MUG

BELLITALIA DESIGN



UNTIL **10%**

MUG

BELLITALIA DESIGN

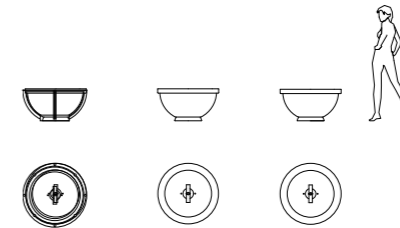
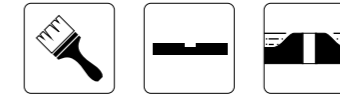

Ø 860 mm
H 451 mm
140 kg
80 lt

Ø 900 mm
H 435 mm
125 kg
80 lt



MATERIALS / MATERIALI / MATERIALES / MATÉRIAUX:

NATURAL MARBLE STONES	WHITE GRANITE	GREY CONCRETE
PIETRE DI MARMO NATURALI	GRANITO BIANCO	CEMENTO GRIGIO
PIEDRAS DE MÁRMOL NATURAL	GRANITO BLANCO	HORMIGÓN GRIS
PIERRES DE MARBRE NATURELLES	GRANIT BLANC	CIMENT GRIS



FINISHING / FINITURE / ACABADOS / FINITIONS:



ACCESSORIES / ACCESSORI / ACCESORIOS / ACCESSOIRES:

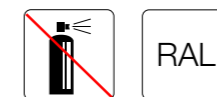

PAWN

BELLITALIA DESIGN

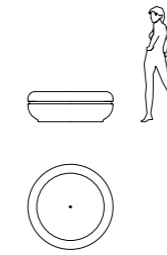
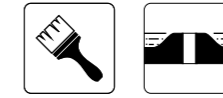

Ø 1200 mm
H 425 mm
620 kg
176 lt



MATERIALS / MATERIALI / MATERIALES / MATÉRIAUX:

NATURAL MARBLE STONES	WHITE GRANITE	GREY CONCRETE
PIETRE DI MARMO NATURALI	GRANITO BIANCO	CEMENTO GRIGIO
PIEDRAS DE MÁRMOL NATURAL	GRANITO BLANCO	HORMIGÓN GRIS
PIERRES DE MARBRE NATURELLES	GRANIT BLANC	CIMENT GRIS



FINISHES / FINITURE / ACABADOS / FINITIONS:



ACCESSORIES / ACCESSORI / ACCESORIOS / ACCESSOIRES:



PRIMAVERA - ESTATE

BELLITALIA DESIGN



PRIMAVERA - ESTATE

BELLITALIA DESIGN





PRIMAVERA - ESTATE

BELLITALIA DESIGN

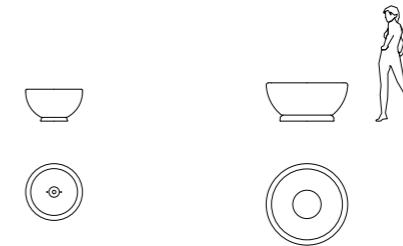
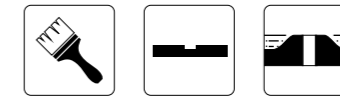

PRIMAVERA

Ø 800 mm
H 450 mm
135 kg
58 lt

ESTATE

L 1150 mm
H 540 mm
594 kg
191 lt

MATERIALS / MATERIALI / MATERIALES / MATÉRIAUX:

NATURAL MARBLE STONES	WHITE GRANITE
PIETRE DI MARMO NATURALI	GRANITO BIANCO
PIEDRAS DE MÁRMOL NATURAL	GRANITO BLANCO
PIERRES DE MARBRE NATURELLES	GRANIT BLANC

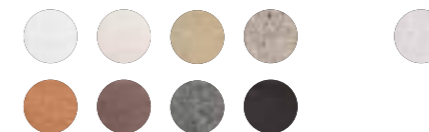

FINISHING / FINITURE / ACABADOS / FINITIONS:

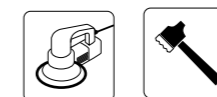

ACCESSORIES / ACCESSORI / ACCESORIOS / ACCESSOIRES:



STELO

BELLITALIA DESIGN





STELO

BELLITALIA DESIGN

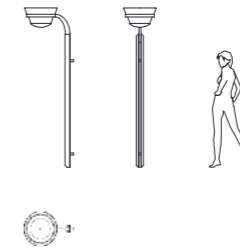

L 500 mm
W 700 mm
H 2496 mm
48 kg
32 lt

MATERIALS / MATERIALI / MATERIALES / MATÉRIAUX:

GALVANIZED STEEL
ACCIAIO ZINCATO
ACERO GALVANIZADO
ACIER GALVANISÉ



FINISHING / FINITURE / ACABADOS / FINITIONS:

RAL

TIMELESS

BELLITALIA DESIGN











TIMELESS

BELLITALIA DESIGN

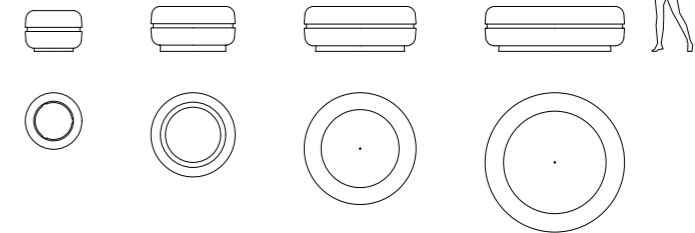
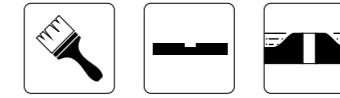

820	1220	1620	2020
Ø 820 mm	Ø 1220 mm	Ø 1620 mm	Ø 2020 mm
H 590 mm	H 650 mm	H 650 mm	H 650 mm
408 kg	910 kg	1468 kg	2114 kg
115 lt	300 lt	600 lt	1019 lt



MATERIALS / MATERIALI / MATERIALES / MATÉRIAUX:

NATURAL MARBLE STONES	WHITE GRANITE	GREY CONCRETE
PIETRE DI MARMO NATURALI	GRANITO BIANCO	CEMENTO GRIGIO
PIEDRAS DE MÁRMOL NATURAL	GRANITO BLANCO	HORMIGÓN GRIS
PIERRES DE MARBRE NATURELLES	GRANIT BLANC	CIMENT GRIS



FINISHING / FINITURE / ACABADOS / FINITIONS:



ACCESSORIES / ACCESSORI / ACCESORIOS / ACCESSOIRES:



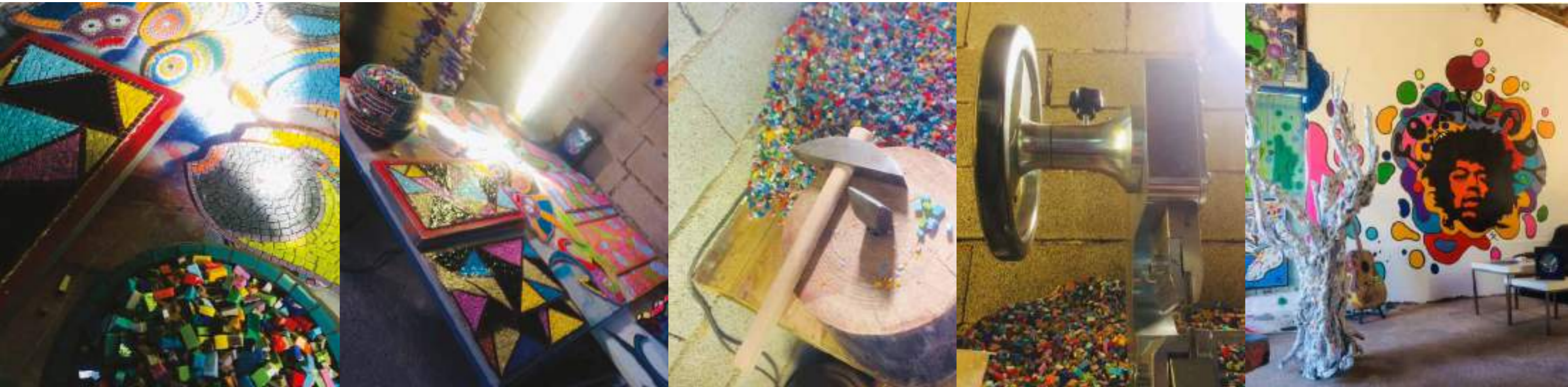

YANNICK ROBERT, aka YR, was born in 1973 in Sète, in the south of France, where he soon set about capturing the light and colours! His undying love for the patterns of light would play a pivotal role in his future choices.

He begins his career by teaching himself mosaic technique — which is complex but provides an outlet for the imagination with its colourful and alternating pieces of tile. His experience builds slowly, starting with the observation of artists such as Gaudí, Niki de Saint Phalle, Dubuffet, Cocteau and Miro, and then continues through travel. In 1997 he set off on a journey to discover Chile, the birthplace of his partner, where he visits to the modest workshops where local artists work to the lull of music; this awakens in him the need to make his mosaics and his art his true profession, as well as his calling in life.

With 2005 comes an important point in his career: his first showroom. Four years later YR starts a great project; he begins to embellish the streets of Palavas le Flots with an intricate and lively decoration of the planters and niches along the sea-front. YR himself suggested to the Municipality and to the Mayor that he undertake this project and only later, in 2013 with a trip to Rome, he learns that the planters in question are produced by Bellitalia.

YR works with sandstone tiles made with Venetian enamel. The creation of the mosaic and the assembling of the various pieces follow a completely personal technique, which at the same time refers to an ancient method adopted by the mosaic masters of ancient Rome.

So a set of identities, artistic figures and techniques converge in his way of making art. You could say YR is a free spirit: he applies his unique style, with its fusion of primitive and contemporary art, to everyday objects — a guitar, a notice-board, planters — turning them into living characters, multi-forms; through colour they are infused with a soul; they become unique.

Through his mosaics YR offers us an authentic, passionate and original look at his time and his way of conceiving art.

YANNICK ROBERT, in arte YR nasce nel 1973 a Sète, nel sud della Francia, di cui ha subito catturato luci e colori! Un amore quello dedicato ai giochi di luce, che ne caratterizzerà le scelte future.

Vede l'inizio della sua carriera con lo studio da autodidatta della tecnica del mosaico, complessa ma in grado di dare sfogo alla fantasia e di prendere vita attraverso tessere colorate e cangianti. La sua esperienza si costruisce pian piano, partendo dall'osservazione di artisti come Gaudí, Niki de Saint Phalle, Dubuffet, Cocteau e Miro, per poi continuare attraverso i viaggi. Nel 1997 parte per un viaggio alla scoperta del Cile, paese natale della sua compagna, dove le visite ai modesti laboratori in cui gli artisti locali lavorano cullati dalla musica, risvegliano in lui la necessità di fare dei suoi mosaici e della sua arte una vera e propria professione, nonché necessità di vita.

Col 2005 arriva un punto importante della sua carriera: il suo primo showroom. Quattro anni dopo nasce un grande progetto, inizia infatti ad abbellire le strade di Palavas le Flots, attraverso una decorazione complessa e vivace delle fioriere e nicchie poste lungo il mare; lui stesso ha proposto al Comune e al Sindaco di intraprendere questo progetto e solo successivamente, nel 2013 con un viaggio a Roma, viene a conoscenza che le fioriere in questione sono di produzione di Bellitalia.

YR lavora con piastrelle di arenaria realizzate con smalto veneziano. La creazione del mosaico e l'assemblaggio dei vari tasselli segue una tecnica completamente personale, ma che allo stesso tempo si rifà ad una tecnica antica adottata dai maestri mosaicisti dell'antica Roma.

Quindi un insieme di identità, di figure artistiche e di tecniche confluiscono nel suo modo di fare arte. Stiamo parlando di uno spirito libero, in grado di trasformare l'arte primitiva e la manifestazione contemporanea in una forma d'espressione tutta personale e unica, che vede applicazione fisica su oggetti di uso quotidiano, come una chitarra, una lavagna oppure delle fioriere, trasformandoli in personaggi viventi, multiformi che attraverso il colore si caricano di un'anima tutta loro e unica.

Attraverso i suoi mosaici YR ci offre uno sguardo autentico, passionale e originale sul suo tempo e il suo modo di concepire l'arte.

SPECIAL PROJECTS





Ø 820 + PONTE

BELLITALIA DESIGN

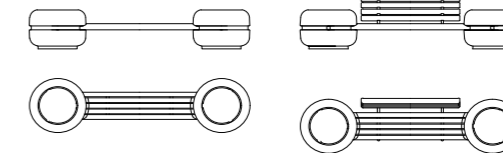
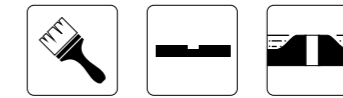

Ø 820 mm
L 3182 mm
H 590 mm
858 kg

Ø 820 mm
L 3182 mm
H 797 mm
876 kg

MATERIALS / MATERIALI / MATERIALES / MATÉRIAUX:

NATURAL MARBLE STONES
PIETRE DI MARMO NATURALI
PIEDRAS DE MÁRMOL NATURAL
PIERRES DE MARBRE NATURELLES

WHITE GRANITE
GRANITO BIANCO
GRANITO BLANCO
GRANIT BLANC

GREY CONCRETE
CEMENTO GRIGIO
HORMIGÓN GRIS
CIMENT GRIS

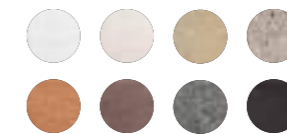

WOOD
LEGNO
MADERA
BOIS



FINISHING / FINITURE / ACABADOS / FINITIONS:



ACCESSORIES / ACCESSORI / ACCESORIOS / ACCESSOIRES:



Ø 1220 + PONTE

BELLITALIA DESIGN

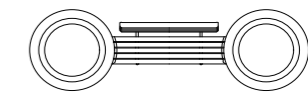
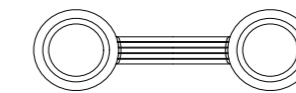
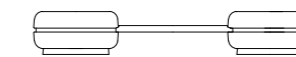
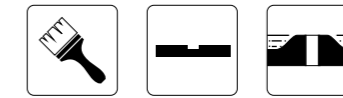

Ø 1220 mm
L 4018 mm
H 650 mm
1862 kg

Ø 1220 mm
L 4018 mm
H 850 mm
1880 kg

MATERIALS / MATERIALI / MATERIALES / MATÉRIAUX:

NATURAL MARBLE STONES
PIETRE DI MARMO NATURALI
PIEDRAS DE MÁRMOL NATURAL
PIERRES DE MARBRE NATURELLES

WHITE GRANITE
GRANITO BIANCO
GRANITO BLANCO
GRANIT BLANC

GREY CONCRETE
CEMENTO GRIGIO
HORMIGÓN GRIS
CIMENT GRIS

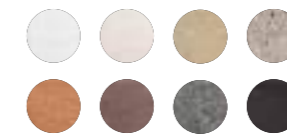

WOOD
LEGNO
MADERA
BOIS



FINISHING / FINITURE / ACABADOS / FINITIONS:



ACCESSORIES / ACCESSORI / ACCESORIOS / ACCESSOIRES:





Ø 1220 + CIRCOLARE

BELLITALIA DESIGN

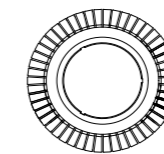
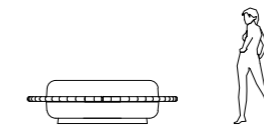
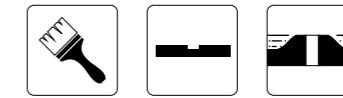

Ø 1760 mm
H 650 mm
990 kg
300 lt

MATERIALS / MATERIALI / MATERIALES / MATÉRIAUX:

NATURAL MARBLE STONES
PIETRE DI MARMO NATURALI
PIEDRAS DE MÁRMOL NATURAL
PIERRES DE MARBRE NATURELLES

WHITE GRANITE
GRANITO BIANCO
GRANITO BLANCO
GRANIT BLANC

GREY CONCRETE
CEMENTO GRIGIO
HORMIGÓN GRIS
CIMENT GRIS

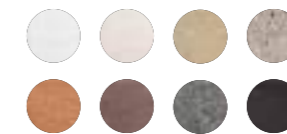

WOOD
LEGNO
MADERA
BOIS



FINISHING / FINITURE / ACABADOS / FINITIONS:



ACCESSORIES / ACCESSORI / ACCESORIOS / ACCESSOIRES:

